



DIGITAL CONTROLLER

TTM-509

Feasible to control 2 inputs maximum per unit
The versatile function, high accuracy $\pm 0.1\%$ and high speed sampling cycle 50ms will expand the wide application range

Features

- **High accuracy · High speed sampling cycle**
High accuracy: $\pm 0.1\%$, high speed sampling cycle: 50ms
- **Variety inputs**
2 inputs can be equipped upon request and variety of input type.
1/100°C can be indicated for 4 wire RTD and RTD.
- **The various controls can be performed per unit**
2 inputs control, cascade control, remote SP, positioning proportional control and so on are selectable by parameters setting.
- **SD card available**
The data log function for recording measurement values and various statuses is installed. The stored data is taken into personal computer and it is readable by EXCEL etc.
- **Variety outputs**
Main control outputs and event outputs can be allocated into multiple functions. (Main outputs: 2, auxiliary outputs: 4)
- **MODBUS protocol available**
The current TTM protocol and MODBUS protocol additionally available.
- **Infrared communication function equipped**
Wireless communication can be performed by using infrared.
- **2ch CT input**
The disconnection under three-phase circuit wires can be detected by using 2ch CT input.
- **Memory bank function**
8 types of control parameters can be stored which is changed by DI and communication.

- **Self-tuning PID (Heating/Cooling)**
The optimum PID constant against control object is automatically calculated. PID constant is calculated when making alteration of setting value, or it is corrected when disturbance/hunting etc occurred.
- **Blind function**
At the request, desirable parameter screen is only displayed and set up.
- **Simplified timer**
ON/OFF setting control is available after some certain interval. Function of ON/OFF alarm output is independently usable.
- **Priority display**
Demanding parameter screens are monitored and set up under operational mode screen. (max. 36 screens)
- **Multiple inputs**
Thermocouple, RTD, voltage, current(1-5VDC shunt resistance 250Ω) . Types of input can be changed by parameter setting.
- **Key allocation function**
AT start/stop, RUN/READY, Timer start/stop, Event start/stop and etc can be allocated into 「FUNC1」 「FUNC2」 「FUNC3」 .
- **Deviation monitor function**
The deviation status can be checked in front monitor.
- **Manual control (Balance-less & Bump-less)**
Manual output function is applicable for versatile applications of instrumentation systems.
- **Digital PV filter**
For abrupt alteration of input value, filter effect is operational on software.
- **PID over-shoot protection**
It is functional to inhibit PID over-shoot.

Front Panel & Key Operation

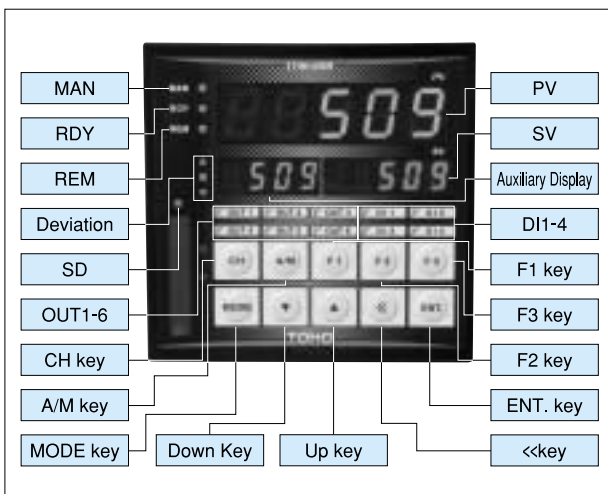

MAN	MAN lamp Lights when remote action	A/M key	A/M key Use when switching auto and manual
RDY	RDY lamp Lights when ready status	F1	F1 key Executes a set function in FUNC setting
REM	REM lamp Lights when remote action	F2	F2 key Executes a set function in FUNC setting
Deviation	Deviation lamp ▲: Deviation high limit lamp ■: Deviation range lamp ▼: Deviation low limit lamp Indicates status between PV and SV	F3	F3 key Executes a set function in FUNC setting
		MODE	MODE key Use when switching displays
		▼ key	▼ key Use when decreasing setting values Push 1s-10s : 1digit/100ms Push 10s-20s : 10 digits/100ms Push 20s or over : 100 digits/100ms
SD	SD card lamp Blinks when SD card accesses Lights when SD card is inserted	▲ key	▲ key Use when increasing setting values Push 1s-10s : 1digit/100ms Push 10s-20s : 10 digits/100ms Push 20s or over : 100 digits/100ms
OUT1-6	OUT1-6 lamp Lights when output is ON		
PV	PV 7seg Measurement values·characters display		
SV	SV 7seg Measurement values·monitor display	<<key	<<key Use when changing setting values
Auxiliary Display	Auxiliary display 7seg Indicates CH etc	ENT.	ENT. key Use when deciding setting data
DI1-4	DI1-4 lamp Light when input is ON		
CH	CH key Use when changing display channels		

Specifications

Input PV1, 2 common	Thermocouple	K, J, T, E, R, S, B, N, (JIS C 1602-1995) U, L, (DIN) W5Re/W26Re, PR40/PR20, PLII (ASTM)		
	R.T.D.	Pt100, JPt100, (JIS C 1604-1997) Pt1000 (External resistance 10Ω or less)		
	Voltage	0-1VDC, 0-5VDC, 1-5VDC, 0-10VDC, 0-10mVDC (Input resistance 1mMΩ or over)		
	Current	4-20mADC (External Input resistance 250Ω)		
	Potentiometer(PV2 only)	135Ω		
	4 wire RTD(PV1 only)	Pt100 (JIS C 1604-1997)		
Display	PV · characters display	5 digits, 7 segments, 2 colors LED: Red · Green 14.2mm(H)		
	SV · setting values	5 digits, 7 segments, LED Red 8mm(H)		
	Auxiliary display	4 digits, 7 segments, LED Orange 8mm(H)		
	Each functions display	LED Red(OUT1-6), Deviation high · low, SD card), LED Green(MAN, RDY, Remote, D1-4, Deviation range)		
Control type	PID	Proportional band(P1)	0.0-200.0% of setting limiter span	
	Auto-tuning	Cooling proportional band(P2)	0.00-10.00xP1(Heating/Cooling action)	
	Self-tuning	Integral time(I)	0-3600sec. (0: Integral action OFF)	
		Deviation time(D)	0-3600sec. (0: Deviation action OFF)	
		Proportional cycle(T1, T2)	1-120sec.	
		Dead band(DB)	Thermocouple/R.T.D.: -100-100, Voltage · Current: -1000-1000	
ON/OFF	Control sensitivity(C1, C2)	Thermocouple/R.T.D.: 0-999, Voltage · Current: 0-99999		
Main output	Relay contact	250VAC, 3A(Load resistance), 1a contact		
	Open collector	24VDC 100mA		
	SSR drive voltage	0-12VDC(Load resistance: 600Ω or more)		
	Voltage	1-5VDC, 0-5VDC, 0-10VDC(Load resistance: 1KΩ or more), 0-1VDC(Load resistance: 500KΩ or more)		
	Current	4-20mADC(Load resistance 600Ω or less)		
Auxiliary output	Relay contact	250VAC, 3A(Load resistance), 1a contact		
	Open collector	24VDC 100mA		
Sampling cycle	0.05sec(Output change period is the same)			
Setting and Indication accuracy	Thermocouple/R.T.D./Voltage/Current	Refer to the table of input, and range of scale		
	Potentiometer	FS ±(0.5%+1 digit)		
Memory element	EEPROM			
Power supply	100VAC-240VAC, 50/60Hz			
Weight	Less than 800g			
Power consumption	Less than 17VA			
Accessories	Instruction manual and installation attachment			
Standard operating condition	23°C ±2°C, 45k-75%RH			
Limit range of operating ambient condition	0-50°C, 20-90%RH(Under non-condensation)			
Limit range of storage ambient condition	-25-27°C, 5-95%RH(Under non-condensation and non-freezing)			
International standard	CE/UL/cUL marking			
Function	Manipulated variable limiter(ML1, MH1, ML2, MH2)	0.0(-10.0: Current/Voltage)-100.0(110.0: Current/Voltage)%		
	Setting limiter(SLL, SLH)	SV setting range low limit-SV setting range high limit		
	Control mode switch (CNT)	PID type(Normal/reverse) ON/OFF(Normal/reverse)		
	PV correction setting 0 point(PVS)	Thermocouple: -199.999°C or -199.9-999.9°C R.T.D.: -199.999°C or -199.9-999.9 or -199.99-999.99°C Current/Voltage: -19999-99999°C		
	PV correction setting gain(PVG)	0.500-2.000 times		
	Input filter(PdF)	0.0-99.9sec		
	Blind function	No indication available for non-required display		
	Priority display	Arbitrary parameter screens are shifted to indication of operation mode by key. (max: 36 screens)		
	Key allocation function	AT start/stop, RUN/READY, Timer start/stop, Event start/stop and etc can be allocated into each FUNC key		
	Timer operation mode	0m:00s-59m:59s 0h:00m-99h:59m Accuracy: setting time ±(1.5%+0.5sec)		
	Watchdog function	Data checked by EEPROM (Err0), A/D converter check (Err1), and Auto-tuning check (Err2), Built-In watchdog timer		
	Initial setting function	Parameters setting can be returned to initial setting.		
	Memory bank	8 types of parameters setting can be stored(only control setting)		
	Buzzer	Buzzer can be sounded by event and by key operation		
	Deviation monitor	Deviation status is displayed		
Other functions	Polygonal line approximation, Extraction square root			

Options

	Specification		Specification
Event output(AL)	Function:PV contact output(8 modes), special contact output(3 modes), additional functions(3 modes) Setting range:-199.9-999.9 or -1999-9999(°C) Sensitivity:0.0-999.9 or 0-9999(°C) Contact polarity is selectable, either normal open or normal close	Communication	RS-485 conformable: Multi-drop 2 line system 1:31 stations max RS-232C conformable: 3 line system 1:1 Communication Parameter: BBC check/Non-BBC check, 7 bits/8bits. Non-parity/odd number/even number, stop-bit 1/2 Communication Speed: 1200/2400/4800/9600/19200 BPS Communication Address: 1-99 Response delay time: 0-250msec Protocol: TOHO TTM protocol, MODBUS(RTU/ASCII)
			Infrared communication
DI	Function:SV/SV2 switchable(OFF: SV2), Auto/Manual switchable(OFF: Manual), Run/Ready switchable(OFF: Ready), Normal/Reverse switchable(OFF: Normal), Normal (SV2)/Reverse(SV2) switchable(OFF: Normal SV2), Timer start/reset(OFF: Counting) Input Spec:Minimum input time: 500ms, OFF voltage: 6DC max, ON current: 6mA max,Permissible resistance value between contacts: ON 333Ωmax, OFF=500kΩmin	Analogue output	0-1VDC, 0-5VDC, 1-5VDC, 0-10VDC, 4-20mADC accuracy ±0.3%
		Data log	SD card(Formatted FAT 16 only), 1-9999sec, Calendar backup 10years
CT input	Setting range:0-30A/AC, 0-100A/AC 2 points, Accuracy 5% (Setting resolution 1A)	Voltage for sensor drive	12VDC 50mA max accuracy ±10VDC
Heating/Cooling	Refer to the specification of output control		

Input and Range (Thermocouple & R.T.D. switchable by key)

Thermocouple		Setting Range/Display Range		Measurement Accuracy
		Non-decimal point	Decimal point	
K	°C	-200 - 1372	-200.0 - 1372.0	(±0.1% or ±0.5°C of PV)±1 digit either of bigger numerical value is taken. ±1°C±1 digit under -100°C
J	°C	-200 - 1200	-200.0 - 1200.0	(±0.1% or ±0.5°C of PV)±1 digit either of bigger numerical value is taken. ±1°C±1 digit under -100°C
T	°C	-200 - 400	-200.0 - 400.0	(±0.1% or ±0.5°C of PV)±1 digit either of bigger numerical value is taken. ±1°C±1 digit under -100°C
E	°C	-200 - 1000	-200.0 - 1000.0	(±0.1% or ±0.5°C of PV)±1 digit either of bigger numerical value is taken. ±1°C±1 digit under -100°C
R	°C	-50 - 1768	- 50.0 - 1768.0	(±0.1% or ±1.0°C of PV)±1 digit either of bigger numerical value is taken. ±1.5°C±1 digit under -100°C
S	°C	-50 - 1768	- 50.0 - 1768.0	(±0.1% or ±1.0°C of PV)±1 digit either of bigger numerical value is taken. ±1.5°C±1 digit under -100°C
B	°C	0 - 1800	0 - 1800.0	(±0.1% or ±1.0°C of PV)±1 digit either of bigger numerical value is taken. No regulation under 400°C
N	°C	-200 - 1300	-200.0 - 1300.0	(±0.1% or ±1.0°C of PV)±1 digit either of bigger numerical value is taken. ±2.0°C±1 digit under -100°C
U	°C	-200 - 400	-200.0 - 400.0	(±0.1% or ±1.0°C of PV)±1 digit either of bigger numerical value is taken. ±2.0°C±1 digit under 0°C
L	°C	-200 - 900	-200.0 - 900.0	(±0.1% or ±1.0°C of PV)±1 digit either of bigger numerical value is taken. ±2.0°C±1 digit under 0°C
W5Re/W26Re	°C	-200 - 2300	-200.0 - 2300.0	(±0.2% or ±1.0°C of PV)±1 digit either of bigger numerical value is taken.
PR40/PR20	°C	0 - 1880	0 - 1880.0	±9.4°C±1 digit No regulation under 800°C
PLI	°C	0 - 1390	0 - 1390.0	(±0.1% or ±0.5°C of PV)±1 digit either of bigger numerical value is taken.

R.T.D.		Setting Range/Display Range		Measurement Accuracy
		Non-decimal point	Decimal point	
Pt100Ω	°C	-200 - 850	-200.0 - 850.0	(±0.1% or ±0.5°C of PV)±1 digit either of bigger numerical value is taken. However, if the decimal point position is second place at the display, ±0.2%±1 digit of PV
		-120 - 120	-120.0 - 120.0 -120.00 - 120.00	
JPt100Ω	°C	-200 - 510	-200.0 - 510.0	
		-120 - 120	-120.0 - 120.0 -120.00 - 120.00	
Pt1000Ω	°C	-200 - 510	-200.0 - 510.0	(±0.1% or ±0.2°C of PV)±1 digit either of bigger numerical value is taken. However, if the decimal point position is second place at the display, ±0.2%±1 digit of measurement temp. range
		-120 - 120	-120.0 - 120.0 -120.00 - 120.00	
Pt100(4wire)	°C	-200 - 510	-200.0 - 510.0	
		-120 - 120	-120.0 - 120.0 -120.00 - 120.00	

Current · Voltage		Setting Range/Display Range		Measurement Accuracy
		Non-decimal point	Decimal point	
0-1VDC	V	-1999-99999 (Display range under 300000)	Decimal point can be changed by key	±0.1%±1 digit of FS
0-5VDC	V			
1-5VDC	V			
0-10VDC	V			
0-10mVDC	mV			
0-20ADC	mA			±0.15%±1 digit of FS
				±0.1%±1 digit of FS

Potentiometer	%	-10-110	———	±0.5%±1 digit of FS
---------------	---	---------	-----	---------------------

Wiring

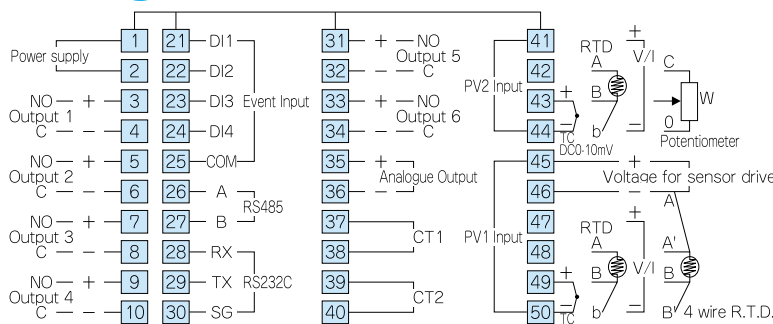

Terminals

Relay Output	C: Common, NO: Normal Close
DI	No polarity, however terminal No. 21-24 will be + when input with open collector
Communication	T/R(A), T/R(B) do not mis-wiring the terminal Not possible to use RS-485 and RS-232C at same time
SG	Use as signal grand of communication
SSR drive voltage	Connect +,- input of SSR side directly
CT	Connect specific CT (heater current detector) directly
R.T.D. input	Connect A,B,b terminals with care
Thermocouple/Current/Voltage input	Connect with care on polarity of + & -
Output	Connect with care on polarity of + & -
Current · Voltage output	Connect with care on polarity of + & -

Operation Flow

- In operation mode, display will be changed to 「Setting Mode Selection」 by pressing MODE key for 3 sec.
Setting categories should be selected by ▲/▼, and setting mode of each categories will be changed by pushing ENT. key

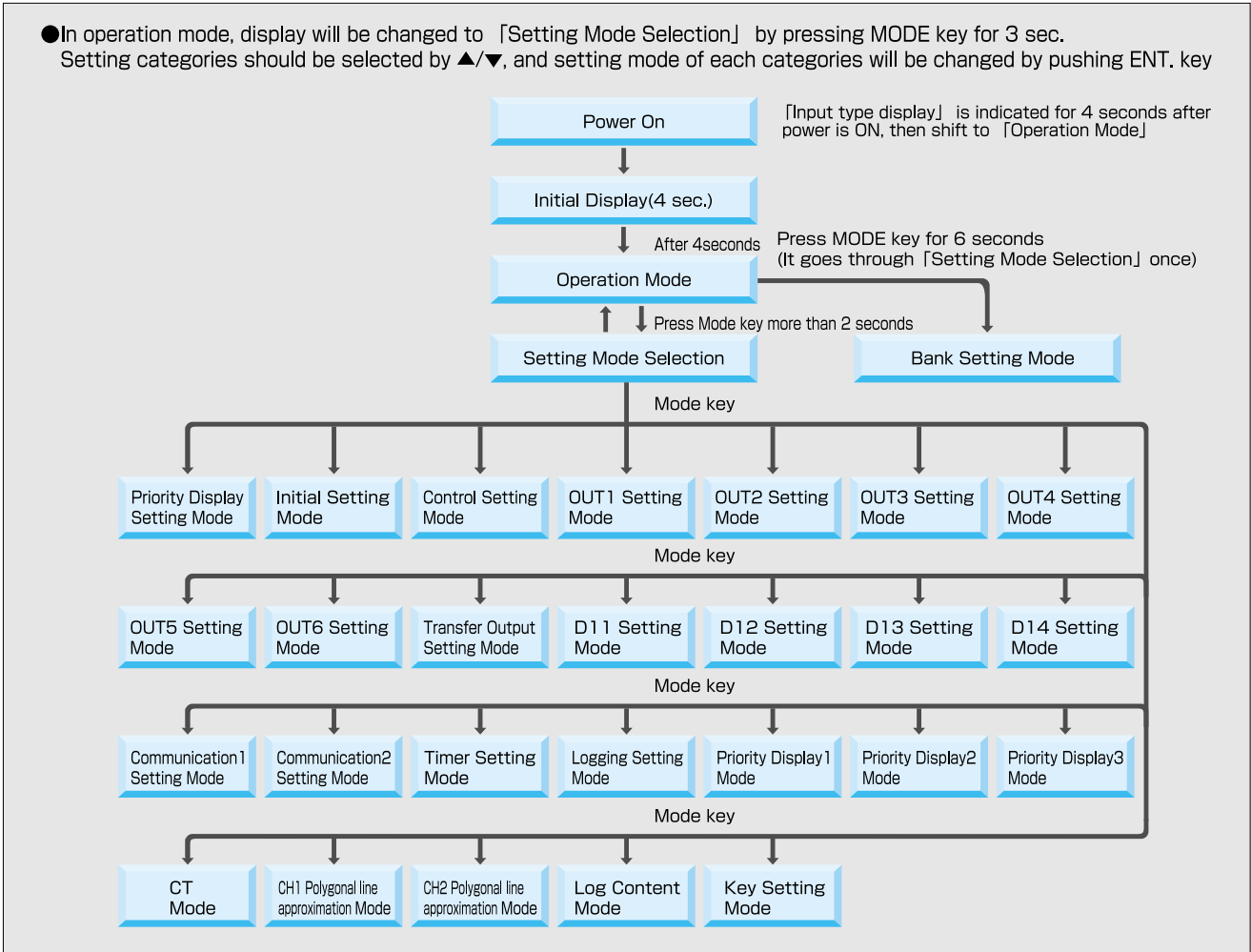

Output Function Allocation

R.T.D.	OUT1	OUT2	OUT3	OUT4	OUT5	OUT6	Transfer
CH1 Main Output	○	○	○	○	○	○	×
CH1 Sub. Output	○	○	○	○	○	○	×
CH2 Main Output	○	○	○	○	○	○	×
CH2 Sub. Output	○	○	○	○	○	○	×
Analogue Output	○*1	○*1	×	×	×	×	○
Event1 Output	○	○	○	○	○	○	×
Event2 Output	○	○	○	○	○	○	×
Event3 Output	○	○	○	○	○	○	×
Event4 Output	○	○	○	○	○	○	×
Event5 Output	○	○	○	○	○	○	×
Event6 Output	○	○	○	○	○	○	×

○ : Possible to allocate function
*1 : Output type can allocate only voltage or current output.

Panel Cut and Dimension

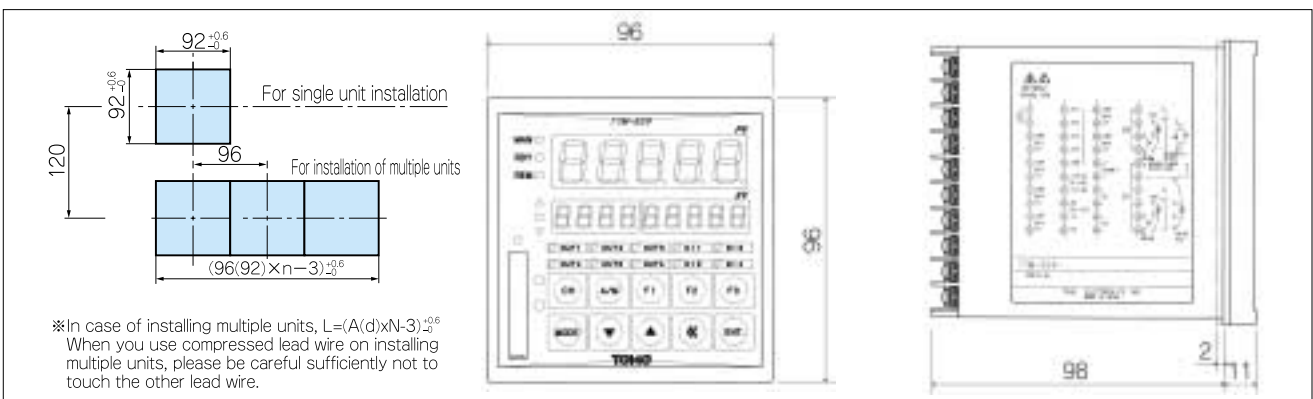

Ordering Information

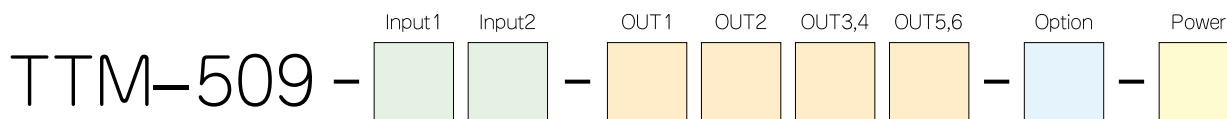

Input1	0	Thermocouple · R.T.D. · Voltage · Current Multiple Input					
	1	4 wire R.T.D. Pt100					
Input2	N	Nil					
	0	Thermocouple · R.T.D. · Voltage · Current · Potentiometer Multiple Input	Not available when 4 wire R.T.D. Pt100 is selected in Input1				
OUT1	N	Nil					
	R	Relay contact					
	P	SSR drive voltage					
	A	Open collector					
	K	Voltage 0-1VDC					
	J	Voltage 0-5VDC					
	F	Voltage 1-5VDC					
	G	Voltage 0-10VDC					
	I	Current 4-20mADC					
OUT2	N	Nil					
	R	Relay contact					
	P	SSR drive voltage					
	A	Open collector					
	K	Voltage 0-1VDC					
	J	Voltage 0-5VDC					
	F	Voltage 1-5VDC					
	G	Voltage 0-10VDC					
	I	Current 4-20mADC					
OUT3,4	N	Nil					
	R	Relay contact (Common Independent)					
	P	SSR drive voltage					
	A	Open collector					
	K	Voltage 0-1VDC					
	J	Voltage 0-5VDC					
	F	Voltage 1-5VDC					
	G	Voltage 0-10VDC					
	I	Current 4-20mADC					
OUT5,6	N	Nil					
	A	Open collector					
	R	Relay contact (Common Independent)					
Option(Plural No. available)	N	Nil					
	M	Communication(RS-485/RS-232C)					
	D1	CT1 · CT2 Input Measurement Range : 0-50A	Option [D2] is not selectable				
	D2	CT1 · CT2 Input Measurement Range : 0-120A	Option [D1] is not selectable				
	E	Event Input					
	T	Infrared communication					
	Q	Voltage for sensor drive	Not available when 4 wire R.T.D. Pt100 is selected				
	L	Data log function	No SD card				
	K	Transfer Output 0-1VDC	J	Transfer Output 0-5VDC	F	Transfer Output 1-5VDC	Only one can be selected from J, K, F, G, I
	G	Transfer Output 0-10VDC	I	Transfer Output 4-20mADC			
Power	Nil	100-240VAC					



TOHO ELECTRONICS INC.

Head office: 1-13-21, Tanashioda, Sagami-hara Kanagawa 229-1125 Japan.

Phone: +81-42-777-3311 Fax: +81-42-777-3751

E-Mail: overseas@toho-inc.co.jp

Web site: <http://www.toho-inc.co.jp>

● Specifications are subject to change without notice.

Note: The color printed in this catalog may be different from actual color.